

# READ AND SAVE THESE INSTRUCTIONS

**WARNING:** A risk of fire and electrical shock exists in all electrical appliances and may cause personal injury or death. Please follow all safety instructions.

## Fast Brew 12-Cup Coffeemaker

**USE AND CARE GUIDE FOR  
MODELS MEFB1W, MEFB1B**



# IMPORTANT SAFEGUARDS

When using electrical appliances, basic safety precautions should always be followed to reduce the risk of fire, electric shock and injury to persons, including the following:

- Read all instructions before using appliance.
- Do not touch hot surfaces. Use handle.
- Do not immerse cord, plug or coffeemaker unit in water or other liquid. See instructions for cleaning.
- This appliance is not for use by children.
- Close supervision is necessary when any appliance is used near children.
- Unplug from outlet when not in use. Unplug and allow to cool before attaching or removing parts and before cleaning the appliance.
- To disconnect, press power button in OFF position, then remove plug from wall outlet.
- Do not let cord hang over edge of table or counter or touch hot surfaces.
- Do not place on or near a hot gas or electric burner or in a heated oven.
- Only use appliance as indicated in these instructions.
- Carafe must never be used on a range top. Use only the designated carafe for your coffeemaker.
- Do not set a hot carafe on a wet or cold surface.
- Do not use a cracked carafe or a carafe having a loose or weakened handle.
- Do not clean carafe with abrasive cleaners, steel wool pads or other abrasive material.
- Scalding may occur if the lid is removed during the brewing cycles.
- Allow filter basket to cool before removing it from coffeemaker.
- **DO NOT POUR LIQUID OTHER THAN WATER AND THE CLEANING SOLUTION SPECIFIED IN THIS MANUAL INTO THE WATER CHAMBER.** See instructions for cleaning.
- Do not move entire unit when carafe contains hot liquid.
- Do not operate any damaged appliance. Do not operate with a damaged cord or plug, or after the appliance malfunctions or has been dropped or damaged in any manner. Return appliance to the nearest authorized service center for examination, repair, electrical or mechanical adjustment.
- Use attachments only if recommended by the manufacturer.
- Be certain lids are securely in place before operating appliance.
- Do not use outdoors or while standing in a damp area.

- Coffeemaker must be left to cool down for approximately 10 minutes before adding more water.
- **WARNING:** Do not remove bottom cover. No user serviceable parts inside. Repair must be done by authorized service personnel only.

## **SAVE THESE INSTRUCTIONS**

**CAUTION:** A short power supply cord is provided to reduce the risk of personal injury resulting from becoming entangled in or tripping over a longer cord. Extension cords are available from local hardware stores and may be used if care is exercised in their use. If an extension cord is required, special care and caution is necessary. Also the cord must be: (1) marked with an electrical rating of 125 V, and at least 13 A., 1625 W., and (2) the cord must be arranged so that it will not drape over the countertop or tabletop where it can be pulled on by children or tripped over accidentally.

**POLARIZED PLUG:** This appliance has a polarized plug, (one blade is wider than the other). As a safety feature to reduce the risk of electrical shock, this plug is intended to fit in a polarized outlet only one way. If the plug does not fit fully in the outlet, reverse the plug. If it still does not fit, contact a qualified electrician. Do not attempt to defeat this safety feature.

**ELECTRIC POWER:** If the electric circuit is overloaded with other appliances, your appliance may not operate properly. It should be operated on a separate electrical circuit from other appliances.

This product is for household use only.

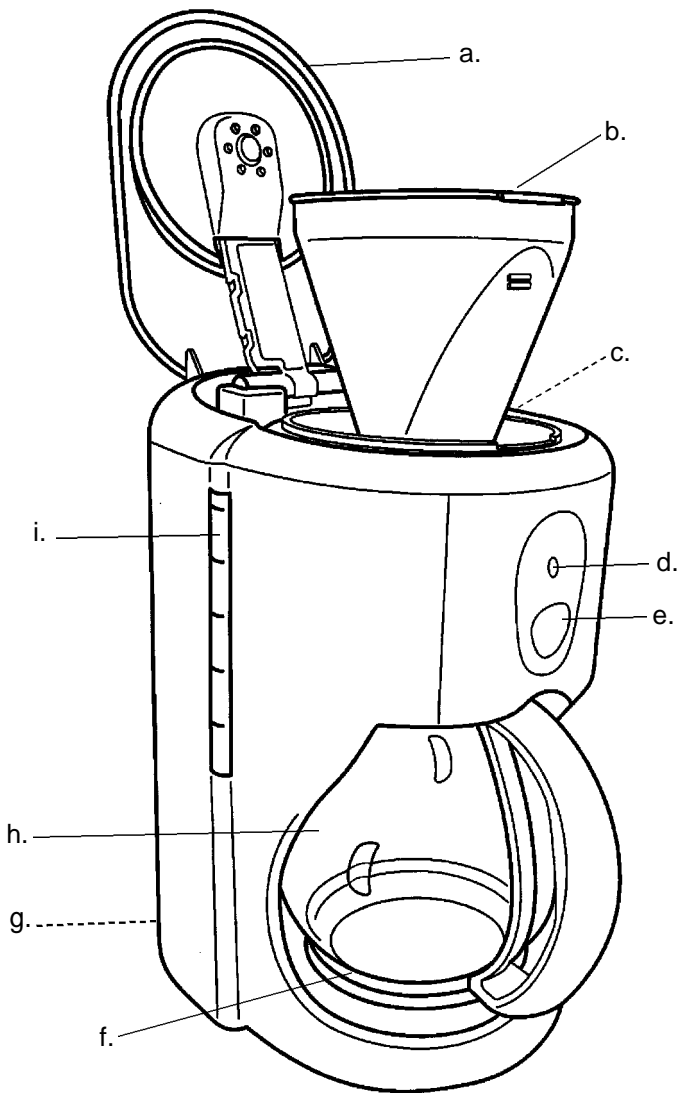

- a. Lid
- b. Filter Basket
- c. Water Chamber
- d. Indicator Light
- e. Power Button
- f. Warming Plate
- g. Cord Storage
- h. Carafe with Lid
- i. Water Level Window

Your product may vary slightly from illustration.

# Before Using Your Coffeemaker

**CAUTION: UNPLUG FROM OUTLET. MAKE SURE POWER BUTTON IS IN OFF POSITION.**

Become familiar with parts of the unit.

Clean the carafe and lid, removable filter basket. Fill the coffeemaker with the maximum amount of water and turn the unit on. Follow procedures for “BREWING” (without coffee). Unplug coffeemaker and discard the water. Wait 10 minutes to allow heating elements to cool. Repeat the process once.

**CAUTION: DO NOT IMMERSE CORD, PLUG, OR COFFEE-MAKER UNIT IN WATER OR OTHER LIQUID.**

## Coffee Yield

A 5-ounce cup is the American industry standard and is used by most coffeemaker manufacturers. Your favorite mug will accommodate about 2 cups (or 10 oz.) of coffee. We do not recommend preparing less than 4 cups (or 20 oz.) of coffee.

## Brewing

1. Push excess cord into cord storage in base of unit. Plug into a 120 V ~ 60 Hz outlet.
2. Make sure the unit is in the OFF position; the indicator light will be off.
3. Markings on the water level window indicate the level of water required to brew the desired number of cups. Remove the snap-on lid by gently pulling up. Fill the carafe with cold tap water. Snap the lid back into position.  
NOTE: Brewing less than 4 cups is not recommended.
4. Lift up the hinged lid on the top of the unit and slowly pour water into the water chamber.
5. Insert a #4 cone paper filter into removable filter basket and add coffee grounds. Use approximately 1 measuring spoon of grounds for every cup of coffee. Close lid.

6. Make sure that the carafe with lid is properly seated on the warming plate. Press the power button in to turn power ON. The indicator light will turn on.
7. If you wish to serve a cup of coffee before brew cycle is complete, simply remove carafe from warming plate. Dripping will automatically cease. Return carafe to position on warming plate within 30 seconds; dripping will resume. If the carafe is not returned to the warming plate, the coffee may overflow from the filter basket.  
NOTE: To keep coffee hot, return carafe to the warming plate after serving. The warming plate will automatically keep ideal serving temperature as long as the coffeemaker is on. Do not let empty carafe remain on heated warming plate.
8. Press the power button to turn the unit OFF when not in use. The indicator light will go off.
9. Unplug and allow to cool for 10 minutes between cycles.

## Helpful Hints for Brewing

- The markings on the water window reflect the quantity of fresh water to be used. The quantity of brewed coffee is less because the coffee grounds absorb water.
- Never use hot or carbonated water. This will damage the appliance.
- Never pour milk, liquid coffee, tea, or other liquid, except water, into the water chamber.

## Care and Cleaning

1. Make sure power button is in OFF position.
  2. Unplug and allow to cool completely before cleaning.
  3. Open hinged lid on top of unit and remove filter basket. Discard coffee grounds and paper filter. Wash and dry all removable parts. Replace basket by fitting notch in groove of unit.
  4. Clean inside of lid and the outside of the coffeemaker with a damp cloth.
- CAUTION: DO NOT IMMERSE CORD, PLUG OR COFFEE-**

**MAKER UNIT IN WATER OR OTHER LIQUID.**

# Descaling

We recommend you clean your coffeemaker once a month with a solution of vinegar and water. Mineral deposits from tap water can form a coating in the coffeemaker, causing slower brewing time and possibly an off flavor in the coffee.

1. Pour ½ cup vinegar into the carafe, and add cold water up to the 4 cup mark. Pour into the water reservoir.
2. Place a clean paper filter in the filter basket and close.
3. Follow brewing instructions, (without coffee.)
4. When the unit has finished brewing, press in the power button to turn the power OFF. Carefully remove the carafe and place on a heat resistant surface. Wait 15 minutes and pour the solution back into the coffee maker.
5. Turn unit ON again. Allow solution to empty into carafe; turn unit OFF. After dripping stops, discard solution.
6. Allow coffeemaker to cool 10 minutes. Rinse it out by brewing a carafe full of cold water, (without coffee). Repeat process.
7. At the end of the cycle, press in the power button to turn power OFF. Discard the water and paper filter.
8. Wash and dry all removable parts.
9. When coffeemaker has cooled, wipe exterior with a damp cloth.

**Any servicing requiring disassembly other than the above cleaning must be performed by an authorized service center.**

## IMPORTANT NOTICE

*If any parts are missing or defective,  
**DO NOT** return this product.*

*Please call our Customer Service Department for assistance.*

**800-233-9054** Monday - Friday 9:00 am - 5:00 pm CST

*Thank You*

# ONE-YEAR LIMITED WARRANTY

This Salton, Inc. product warranty extends to the original consumer purchaser of the product.

**Warranty Duration:** This product is warranted to the original consumer purchaser for a period of one (1) year from the original purchase date.

**Warranty Coverage:** This product is warranted against defective materials or workmanship. This warranty is void if the product has been damaged by accident, in shipment, unreasonable use, misuse, neglect, improper service, commercial use, repairs by unauthorized personnel or other causes not arising out of defects in materials or workmanship. This warranty is effective only if the product is purchased and operated in the USA, and does not extend to any units which have been used in violation of written instructions furnished by Salton, Inc., or to units which have been altered or modified or to damage to products or parts thereof which have had the serial number removed, altered, defaced or rendered illegible.

**Warranty Disclaimers:** This warranty is in lieu of all warranties expressed or implied and no representative or person is authorized to assume for Salton, Inc. any other liability in connection with the sale of our products. There shall be no claims for defects or failure of performance or product failure under any theory of tort, contract or commercial law including, but not limited to, negligence, gross negligence, strict liability, breach of warranty and breach of contract.

**Warranty Performance:** During the above one-year warranty period, a product with a defect will be either repaired or replaced with a reconditioned comparable model (at Salton, Inc. option) when the product is returned to the Salton, Inc. facility within the warranty period and an additional one-month period. No charge will be made for such repair or replacement.

## Service and Repair

Should the appliance malfunction, you should first call toll-free 1-800-233-9054 between the hours of 9:00 am and 5:00 pm Central Standard Time and ask for CUSTOMER SERVICE stating that you are a consumer with a problem.

**In-Warranty Service (USA)** for an appliance covered under the warranty period, no charge is made for service or postage.

**In-Warranty Service (Canada)** for an appliance covered under the warranty period, no charge is made for service or postage. Please return the product insured, packaged with sufficient protection, and postage and insurance prepaid to the address listed below. Customs duty/brokerage fee, if any, must be paid by the consumer.

**Out-of-Warranty Service:** A flat rate charge by model is made for out-of-warranty service. Include \$15.00 (U.S.) for return shipping and handling.

Salton, Inc. cannot assume responsibility for loss or damage during incoming shipment. For your protection, carefully package the product for shipment and insure it with the carrier. Be sure to enclose the following items with your appliance: any accessories related to your problem; your full return address and daytime phone number; a note describing the problem you experienced; a copy of your sales receipt or other proof of purchase to determine warranty status. C.O.D. shipments cannot be accepted.

Return the appliance to:

ATTN: Repair Department, Salton, Inc.  
708 South Missouri St.  
Mcon, MO 63552  
Consumer Service: 1-800-233-9054  
Consumer Parts: 1-800-947-3744 OR 1-800-947-3745  
Hours: 9:00 a.m. - 5:00 p.m. CST

## For more information on Salton, Inc. products:

visit our website: URL <http://www.salton-maxim.com> or  
E-mail us at [SALTON550@aol.com](mailto:SALTON550@aol.com)

**This Melitta product is distributed and serviced by Salton, Inc.**

Printed in China

©1999 Salton, Inc.

©Reg. T.M. of a company of the Melitta Group

Part No.